

Anatomy of a synapse

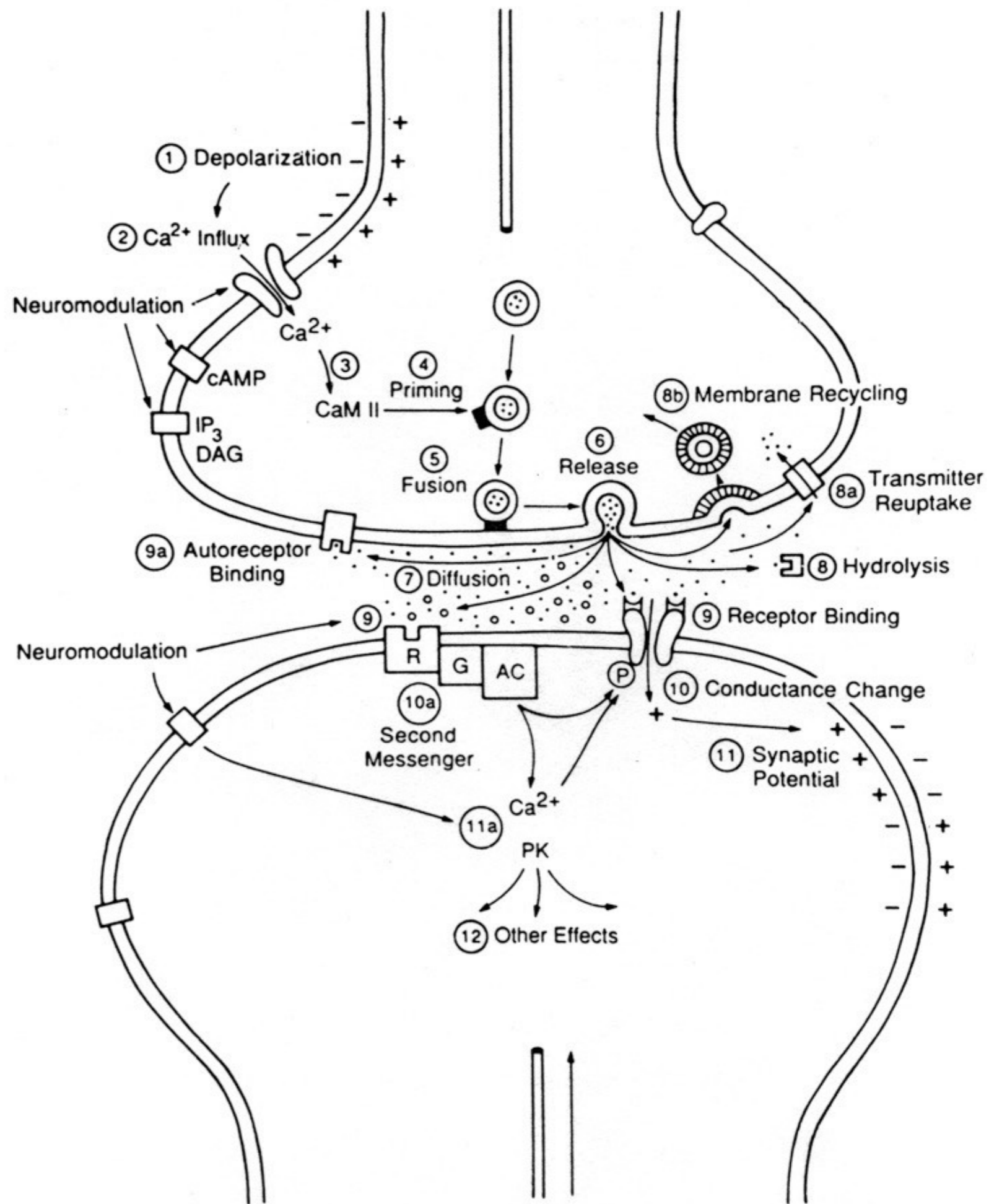

THE SYNAPSE

A Axodendritic

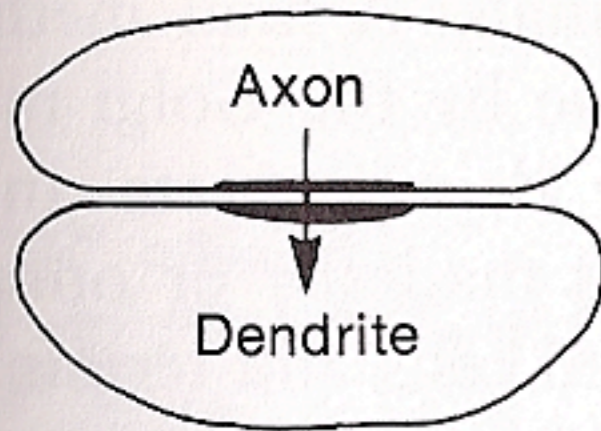

B Dendrodendritic

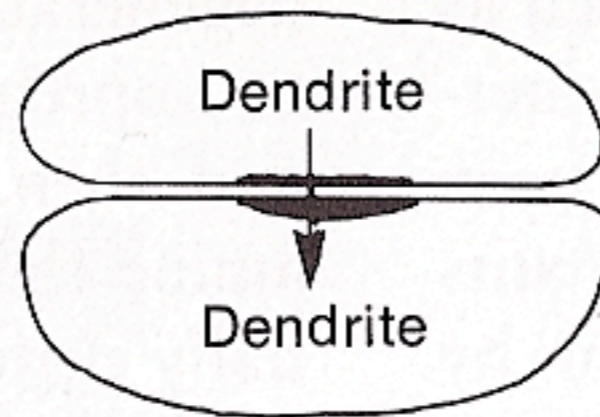

C Axoaxonic

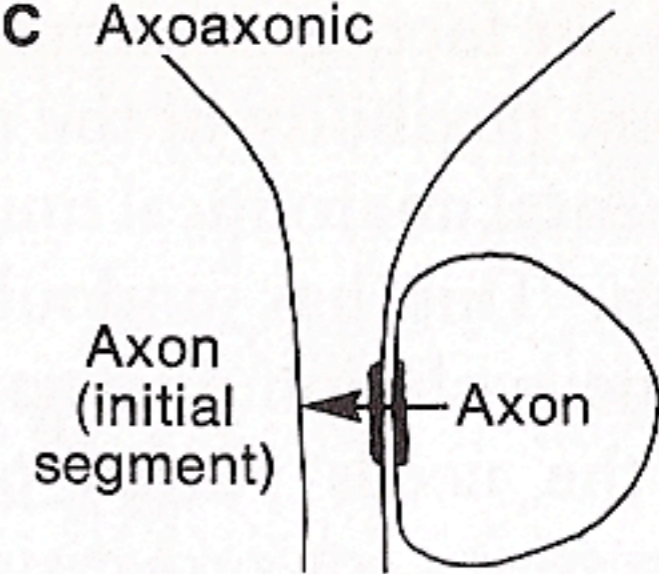

D Reciprocal Synapses

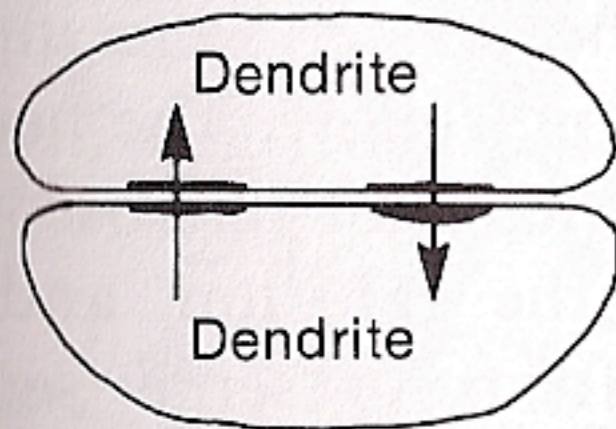

E Serial Synapses
(Axoaxodendritic)

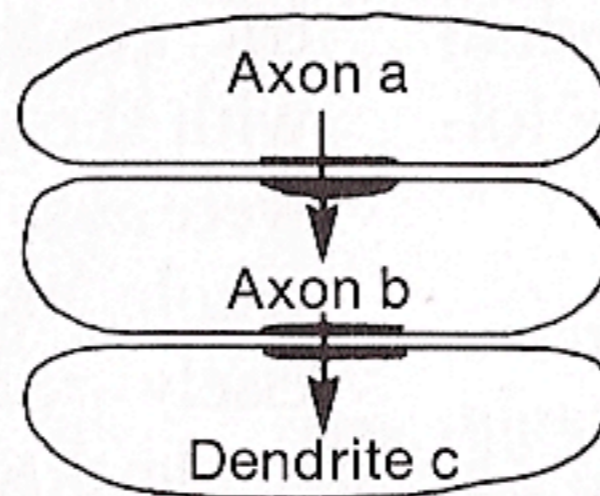

F Synaptic Glomerulus

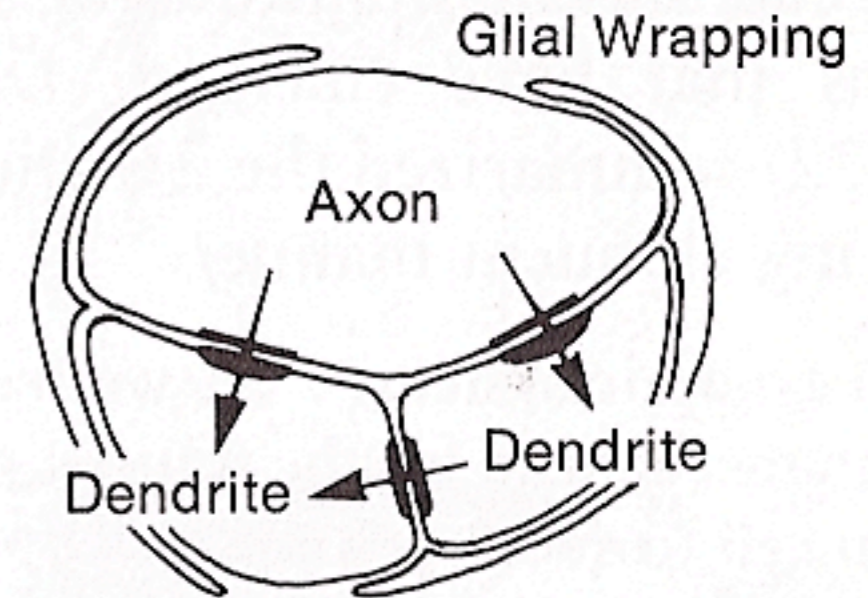

Anatomy of a synapse

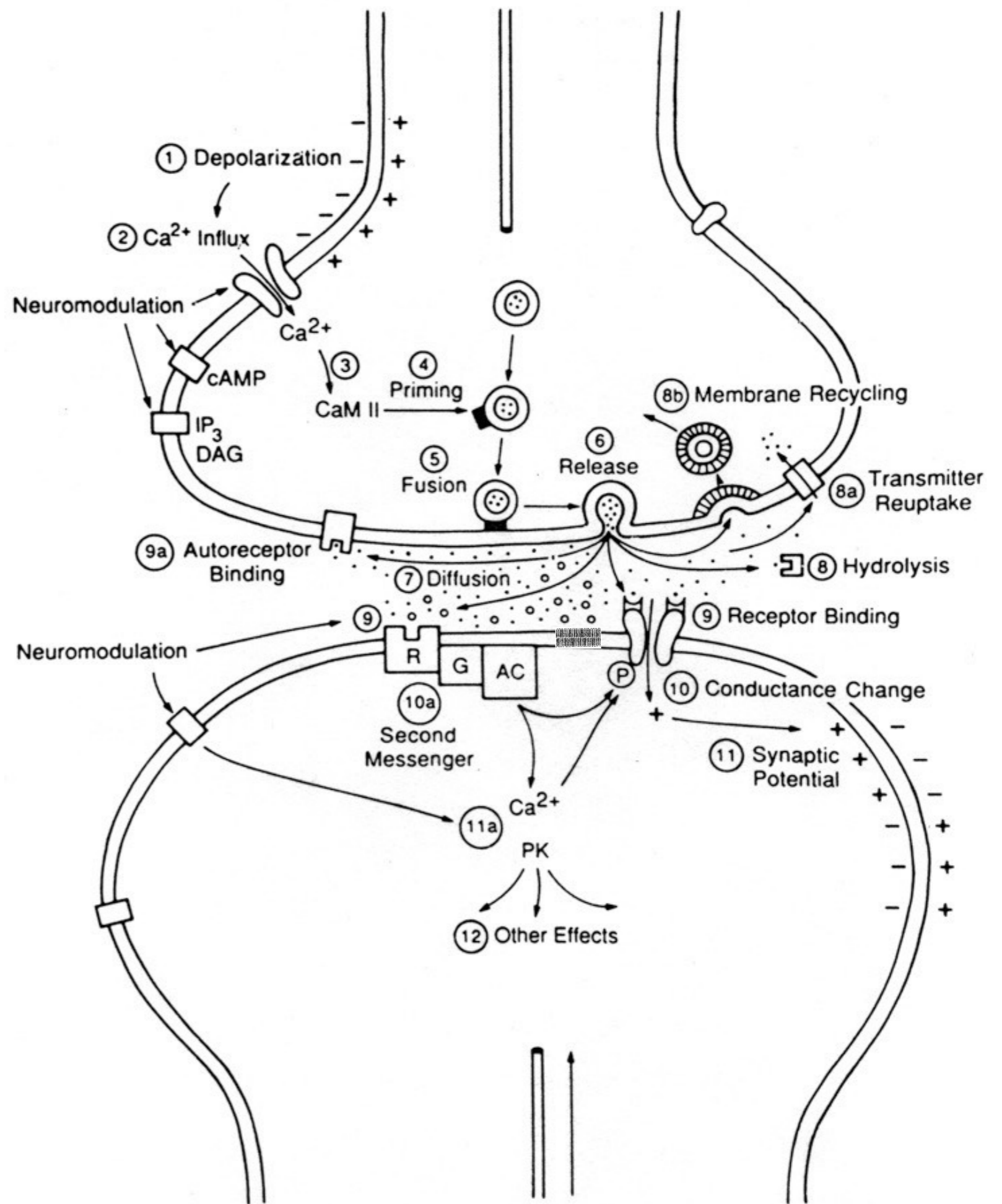

neuron membrane

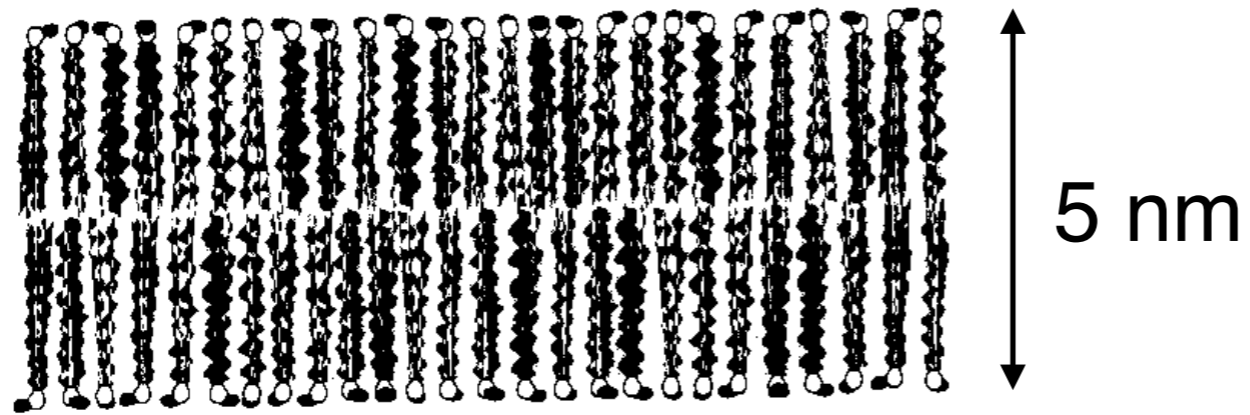

ion channels

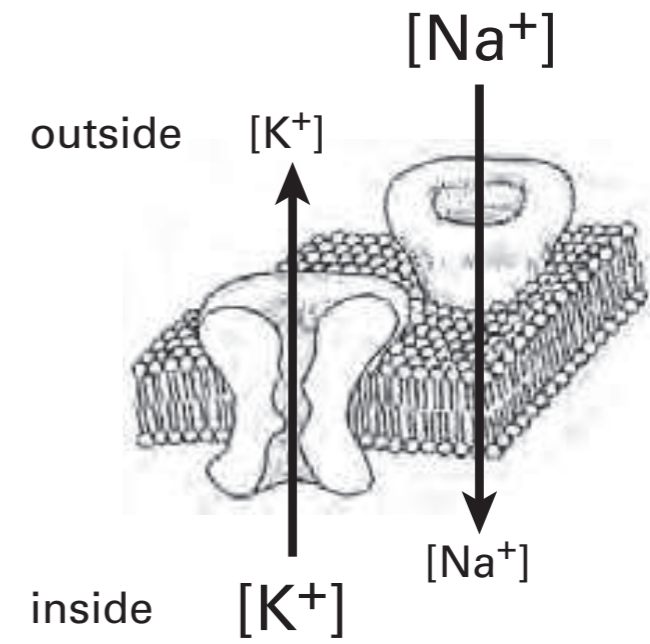

(Whiteboard)

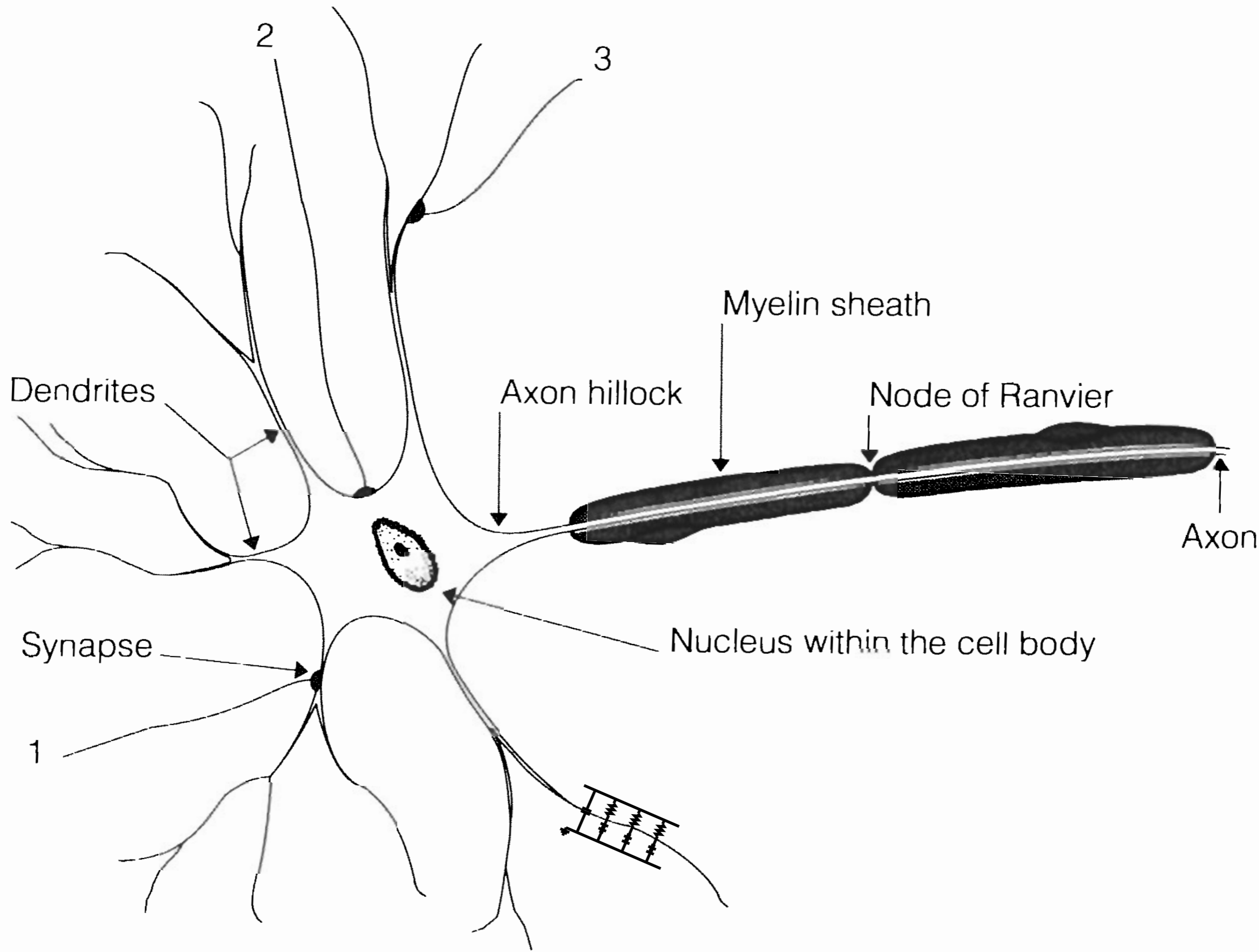

Membrane equation

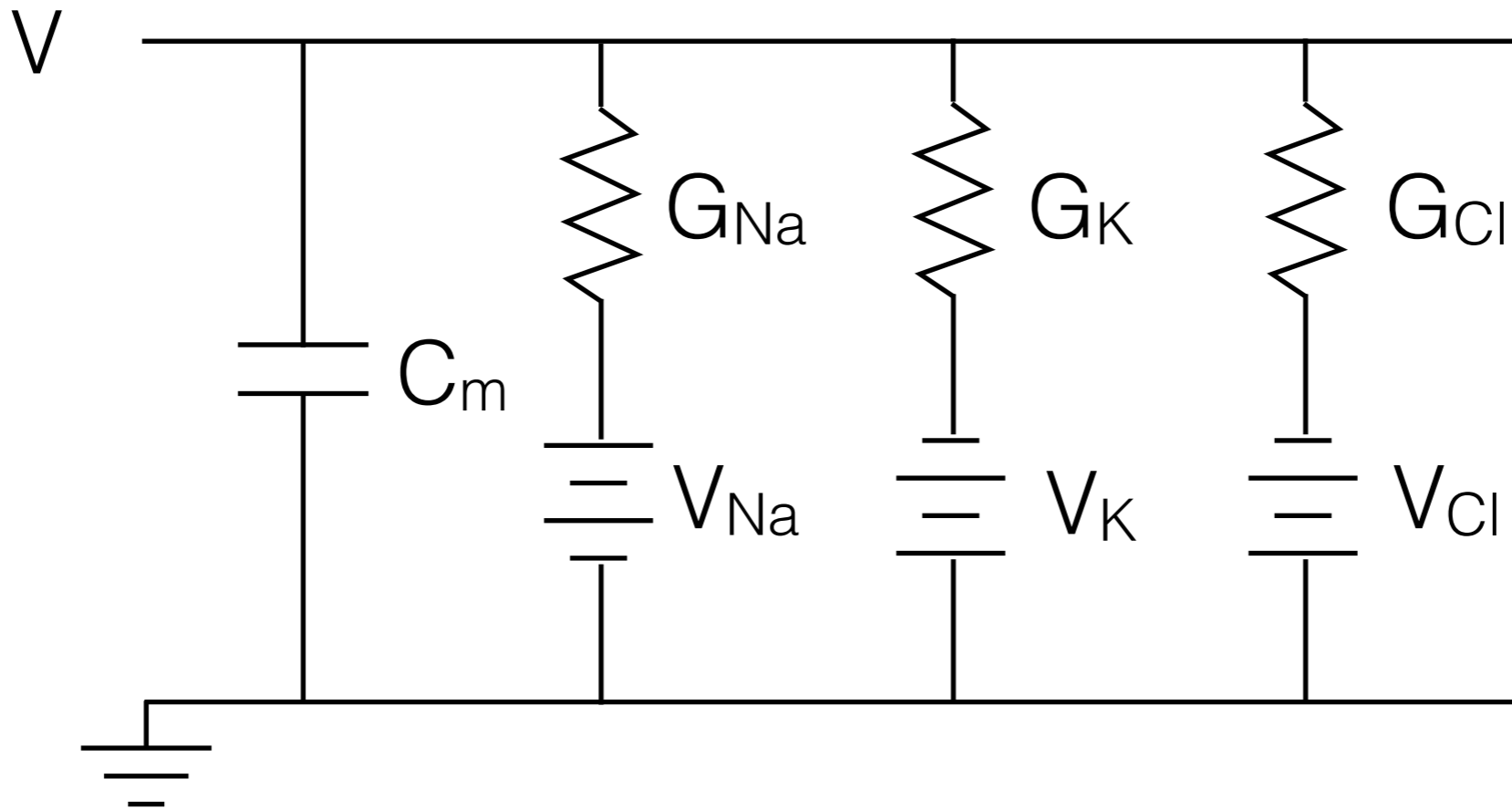

$$\tau \frac{dV}{dt} + V = \frac{V_{Na} G_{Na} + V_K G_K + V_{Cl} G_{Cl}}{G_{total}}$$

$$G_{total} = G_{Na} + G_K + G_{Cl} \quad \tau = \frac{C_m}{G_{total}}$$

Membrane with input current

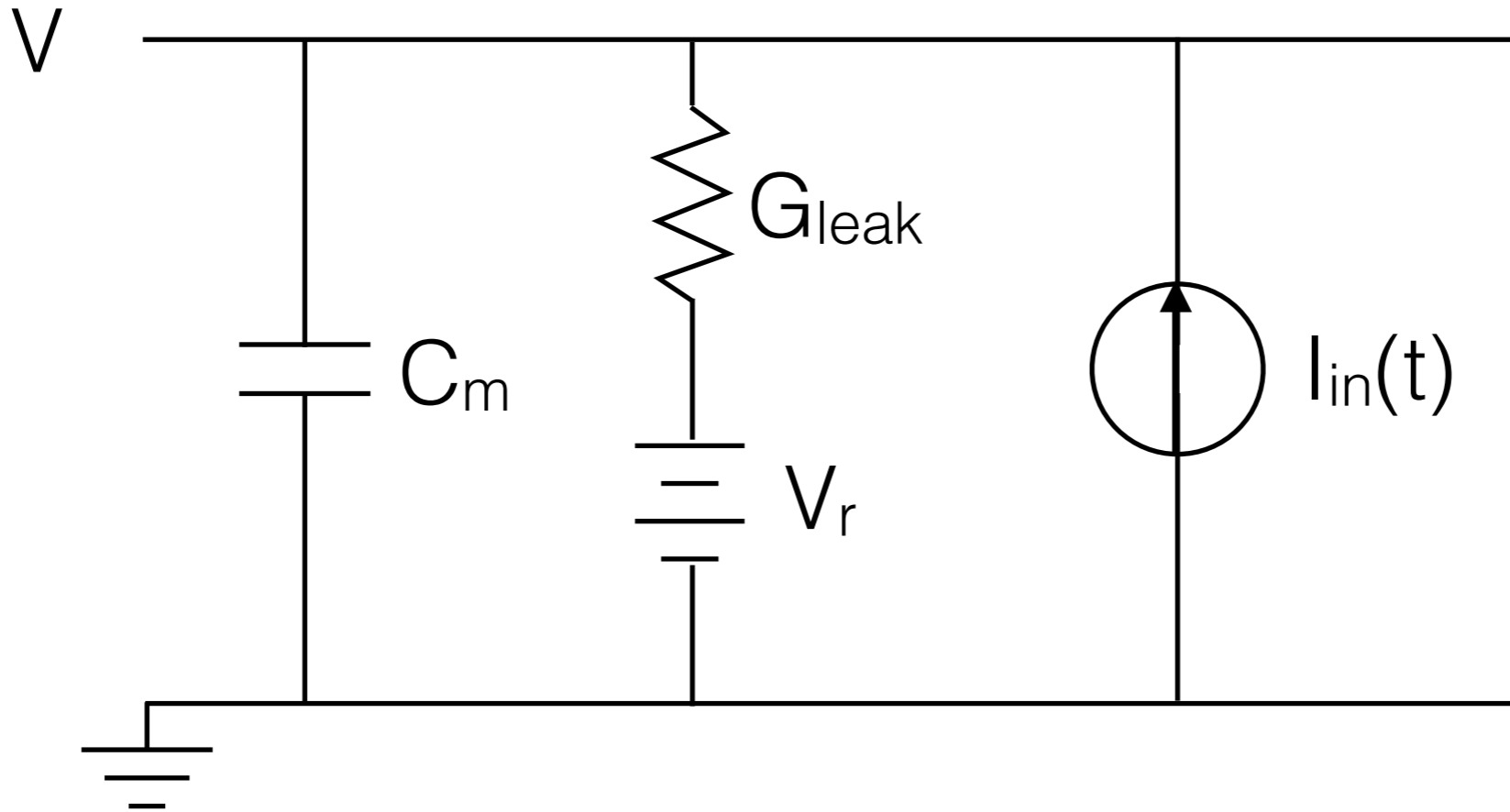

$$\tau \frac{dV}{dt} + V = V_r + \frac{1}{G_{\text{leak}}} I_{\text{in}}(t)$$

$$G_{\text{leak}} = G_{Na} + G_K + G_{Cl} \quad \tau = \frac{C_m}{G_{\text{leak}}}$$

Membrane with synaptic inputs

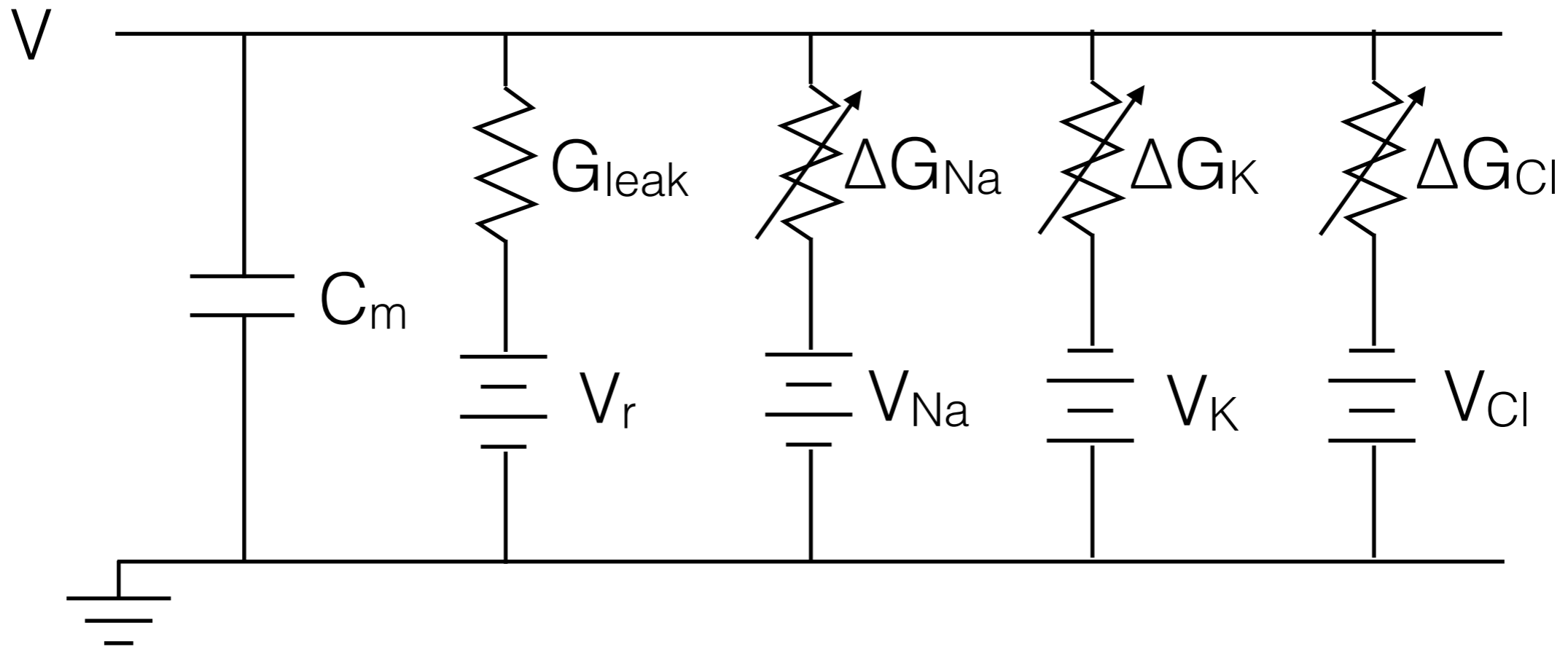

$$\tau \frac{dV}{dt} + V = \frac{V_r G_{\text{leak}} + V_{\text{Na}} \Delta G_{\text{Na}} + V_{\text{K}} \Delta G_{\text{K}} + V_{\text{Cl}} \Delta G_{\text{Cl}}}{G_{\text{total}}}$$

$$G_{\text{total}} = G_{\text{leak}} + \Delta G_{\text{Na}} + \Delta G_{\text{K}} + \Delta G_{\text{Cl}} \quad \tau = \frac{C_m}{G_{\text{total}}}$$

NMDA receptor channel

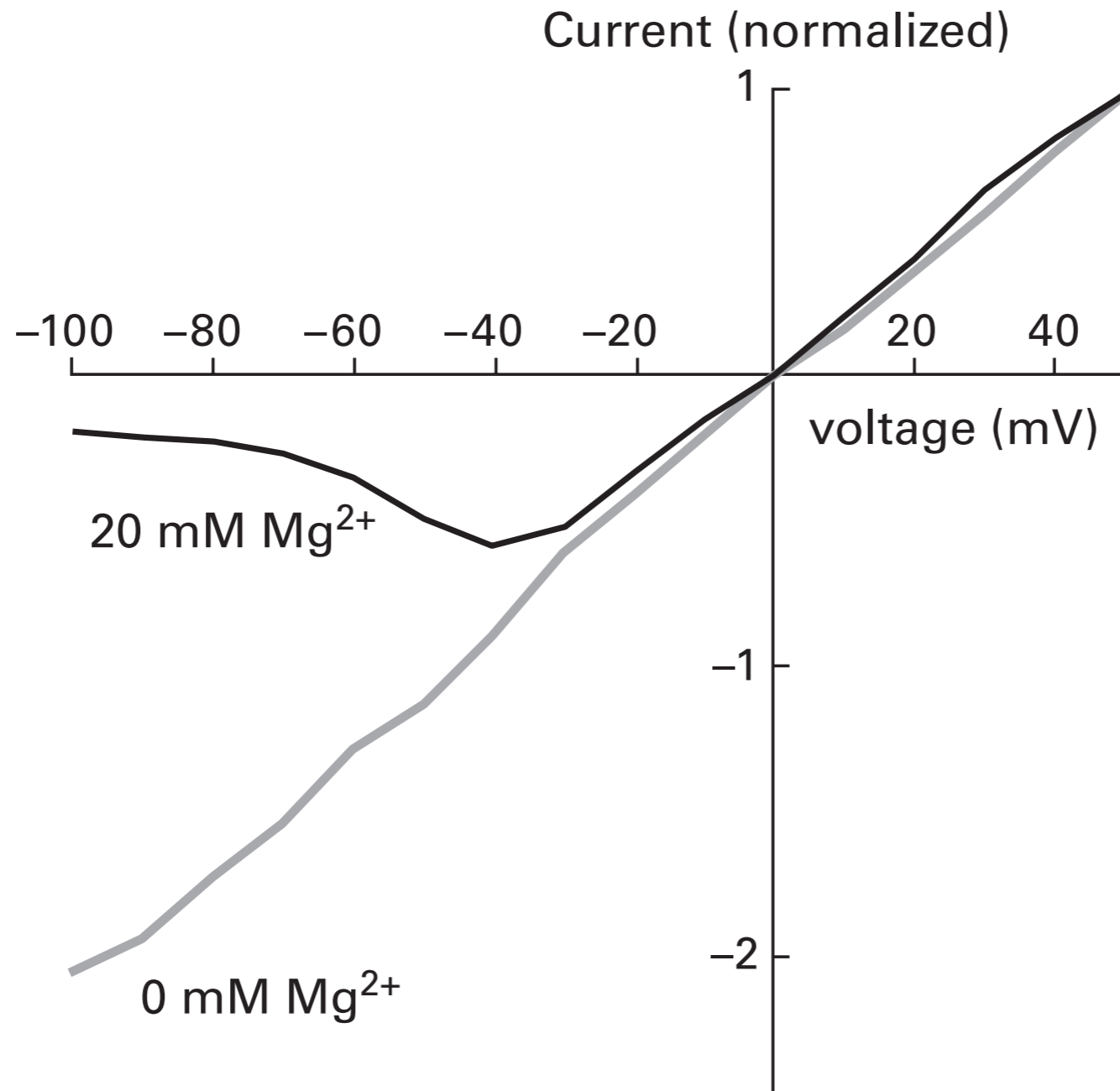

Membrane with synaptic inputs

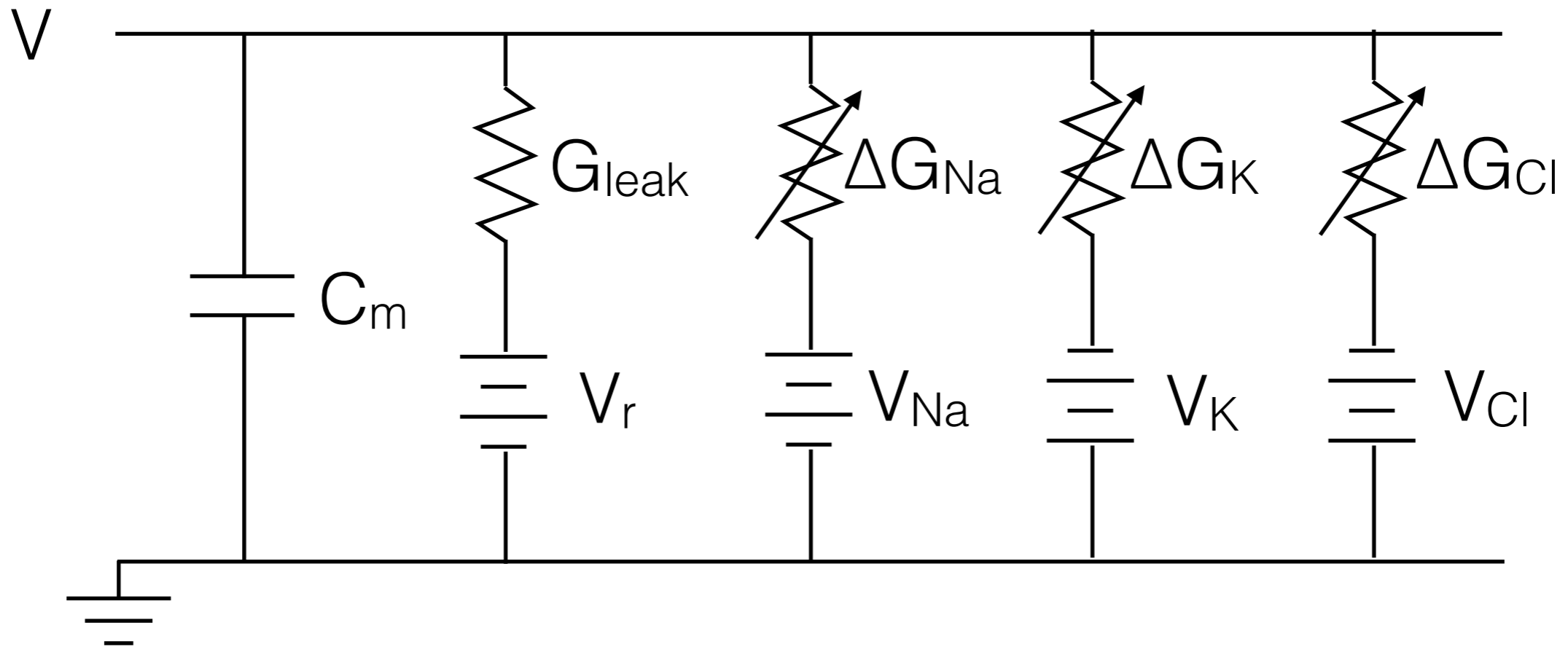

$$\tau \frac{dV}{dt} + V = \frac{V_r G_{\text{leak}} + V_{\text{Na}} \Delta G_{\text{Na}} + V_{\text{K}} \Delta G_{\text{K}} + V_{\text{Cl}} \Delta G_{\text{Cl}}}{G_{\text{total}}}$$

$$G_{\text{total}} = G_{\text{leak}} + \Delta G_{\text{Na}} + \Delta G_{\text{K}} + \Delta G_{\text{Cl}} \quad \tau = \frac{C_m}{G_{\text{total}}}$$

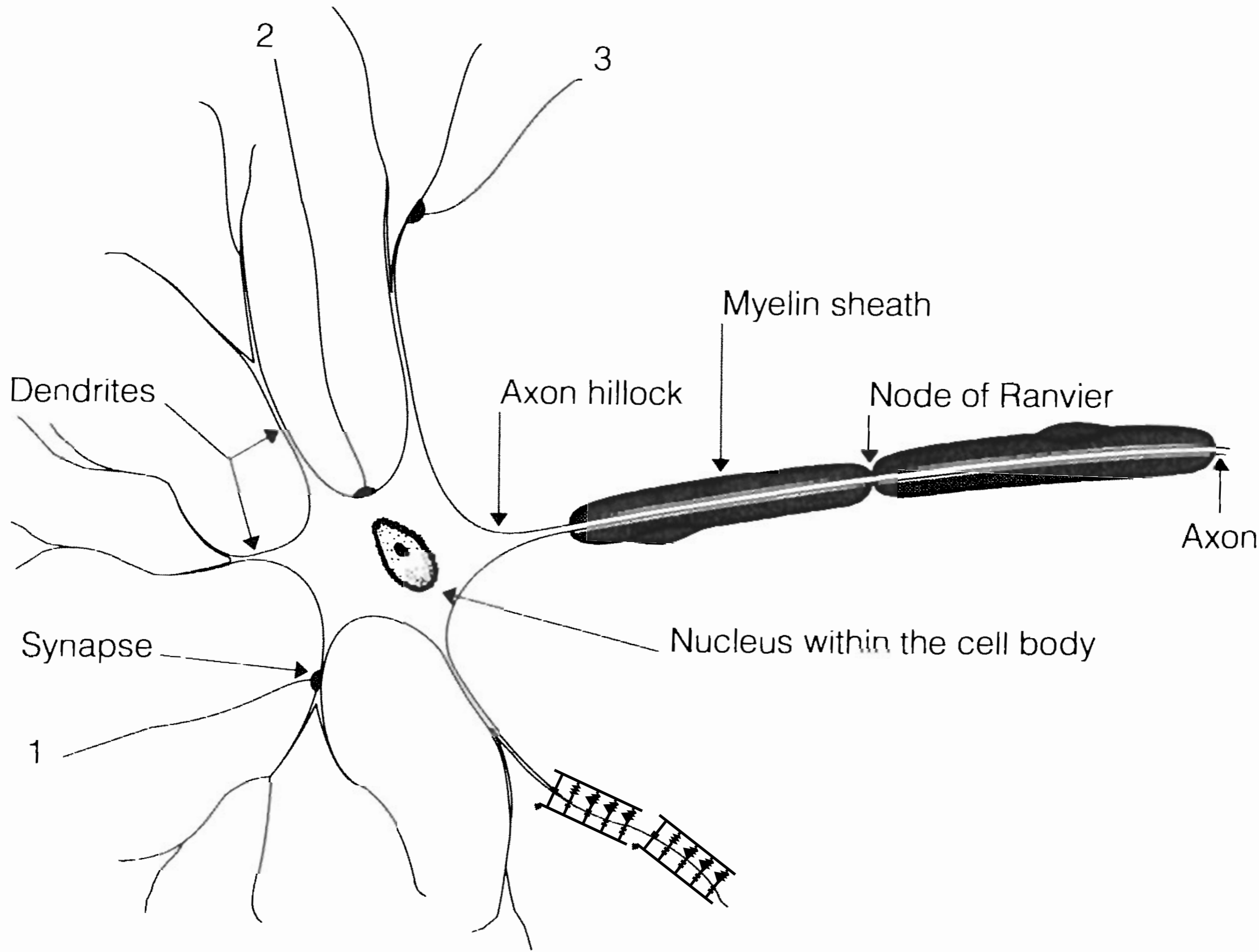

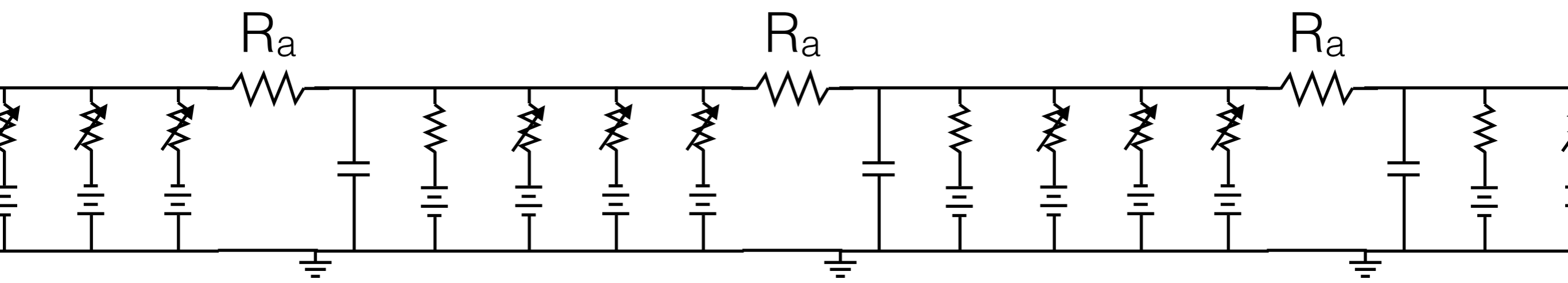

Resistive network

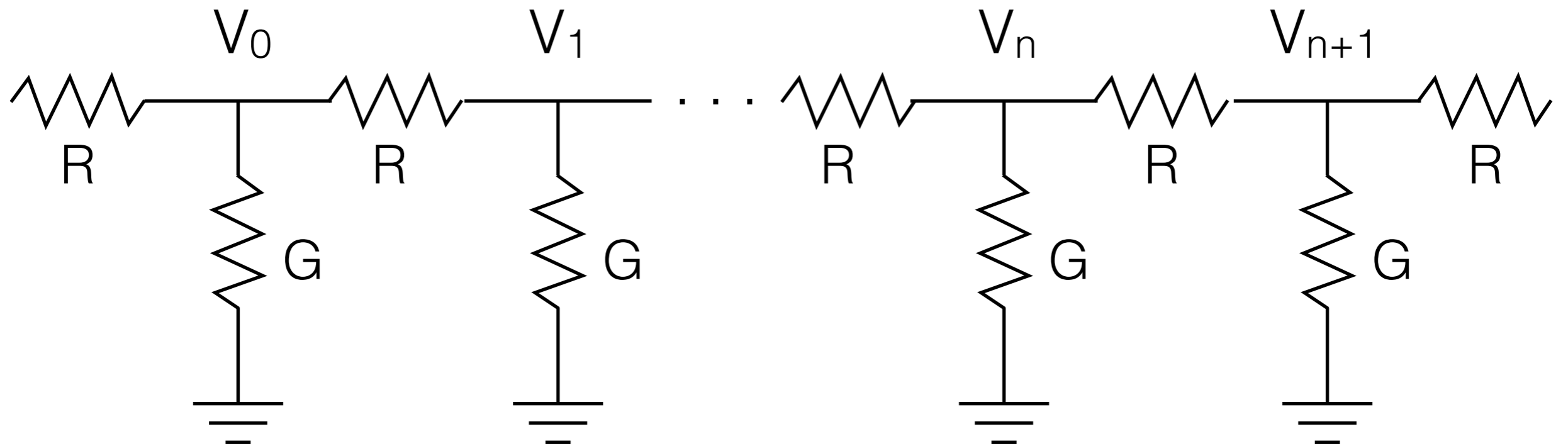

$$\frac{dV}{dx} = -I R$$

$$\frac{dI}{dx} = -V G$$

}

$$\frac{d^2 V}{dx^2} = R G V$$

$$V = V_0 e^{-\frac{|x|}{L}}$$

$$L = 1/\sqrt{R G}$$